

AVAILABLE ACCESSORIES

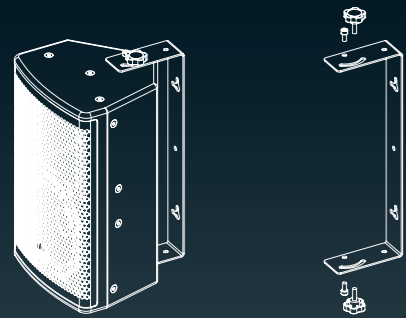

VERTICAL BRACKETS (e.g. Wall Mounting)

Suitable Mounting Brackets for professional Installations.

Available for LDV8 and LDV10.

Article No. LDV8WB / LDV10WB

V-8 / V-10

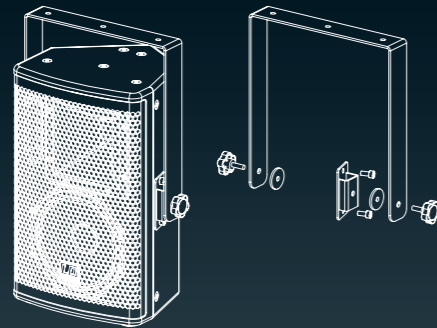

HORIZONTAL SWING BRACKETS (e.g. Truss Mounting)

Suitable Mounting Brackets for professional Installations. Available for all Full-Range Cabinets.

Article No. LDV8SB / LDV10SB / LDV12SB / LDV15SB

V-12 / V-15

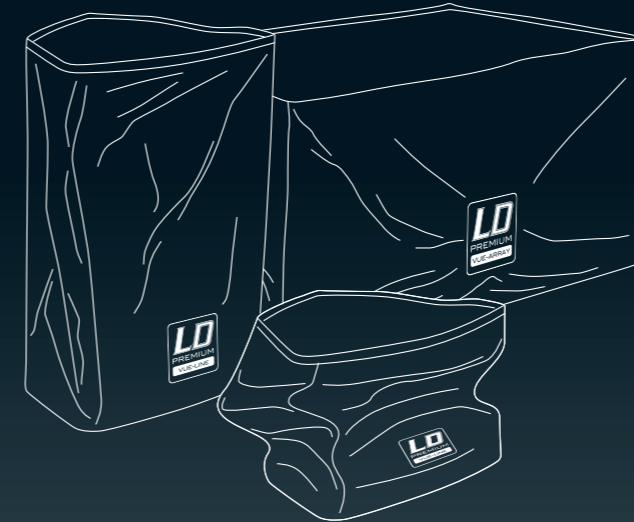
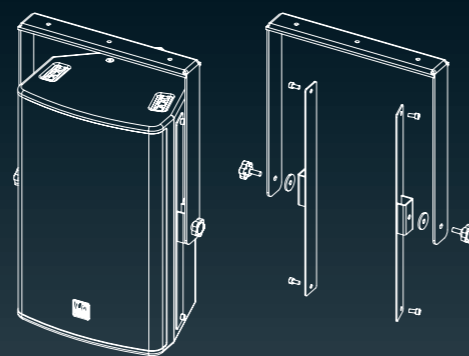

PROTECTION COVER

Waterproofed Premium Transport Bags with stitched Logo. Available for all Models

Article No. LDV8PC / LDV10PC / LDV12PC / LDV15PC

LDV115PC / LDV215PC / LDV218PC



SCREWABLE EYELET M8

Useable for all Full-Range Cabinets.

Article No. LDVSE



CARGO RESTRAINT DOUBLE STUD

Suitable for LDV12 and LDV15. Break-proof until 2400 daN

Article No. 5740

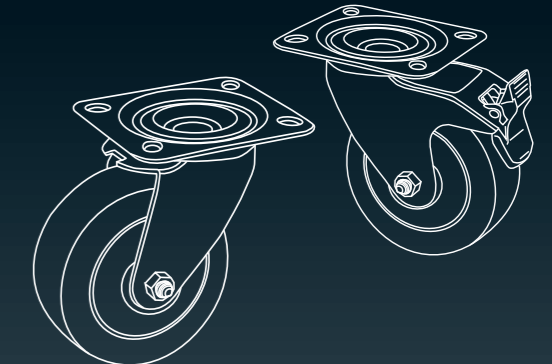

TRANSPORT CASTORS FOR SUBWOOFERS

Swivel Blicke Castor 100mm. double ball race.

Blue polyamid wheel. Height: 125mm. Safe running load per set of four 400 kg.

Article No. 37223 unbraked / 37224 with double Action Brake